

型号: XHD4010B12H

DC BRUSHLESS FAN 40×40×10mm

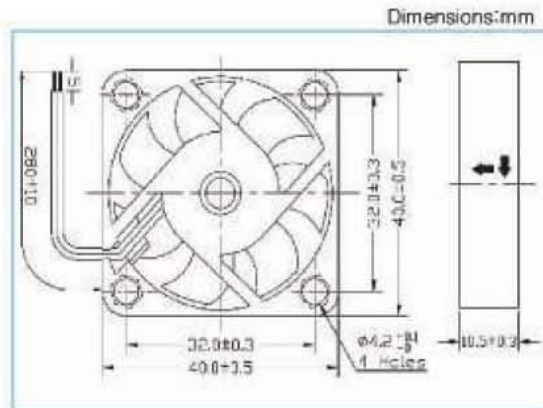

DC FAN GENERAL DATA

Frame Type: Black PBT (UL94V-0)
 Impeller: Black PBT (UL94V-0)
 Bearing: Ball Bearing (1 Ball, 2 Ball) & Sleeve Bearing
 Insulation Resistance: 10M at 500VDC
 Dielectric Withstand: Between lead or terminal and housing
 700VAC for 3 sec or 500 VDC for 1 min
 Life Expectancy: Ambient temperature 25°C and humidity 65%
 Sleeve bearing: 30,000 Hours
 1 Ball bearing: 40,000 Hours
 2 Ball bearing: 50,000 Hours
 Operation Temperature: -10°C~70°C (Ordinary humidity)
 Storage Temperature: -40°C~80°C (Ordinary humidity)
 Lead wire: UL 1007AWG#24/26, +: Red, -: Black, Y: Yellow
 Safety: CE approved, RoHS
 Ingress of Protection: IP44

SPECIFICATION

S: Sleeve Bearing D: 1 Ball Bearing B: 2 Ball Bearing

Frame size (mm)	Speed Define	Bearing Type	Voltage (VDC)	Current (A)	Power (W)	Speed (RPM)	Air Flow (CFM)	Pressure (mm-H ₂ O)	Noise (dBA)	Weight (g)
尺寸	类别	S D B	电压	电流	功率	转速	风量	风压	噪声	重量
40×40×10	H		5	0.20	1.00	6000	5.75	3.49	29.50	15
	M		5	0.14	0.70	5000	4.84	2.54	28.20	15
	L		5	0.09	0.45	4000	3.78	1.53	25.63	15
	HH		12	0.13	1.56	7000	6.56	4.53	33.76	15
	H		12	0.12	1.44	6000	5.75	3.49	29.50	15
	M		12	0.07	0.84	5000	4.84	2.54	28.20	15
	L		12	0.06	0.72	4000	3.78	1.53	25.63	15
	H		24	0.06	1.44	6000	5.75	3.49	29.50	15
	M		24	0.05	1.20	5000	4.84	2.54	28.20	15
	L		24	0.04	0.96	4000	3.78	1.53	25.63	15